

COOL MUSCLE

Integrated Actuator Systems

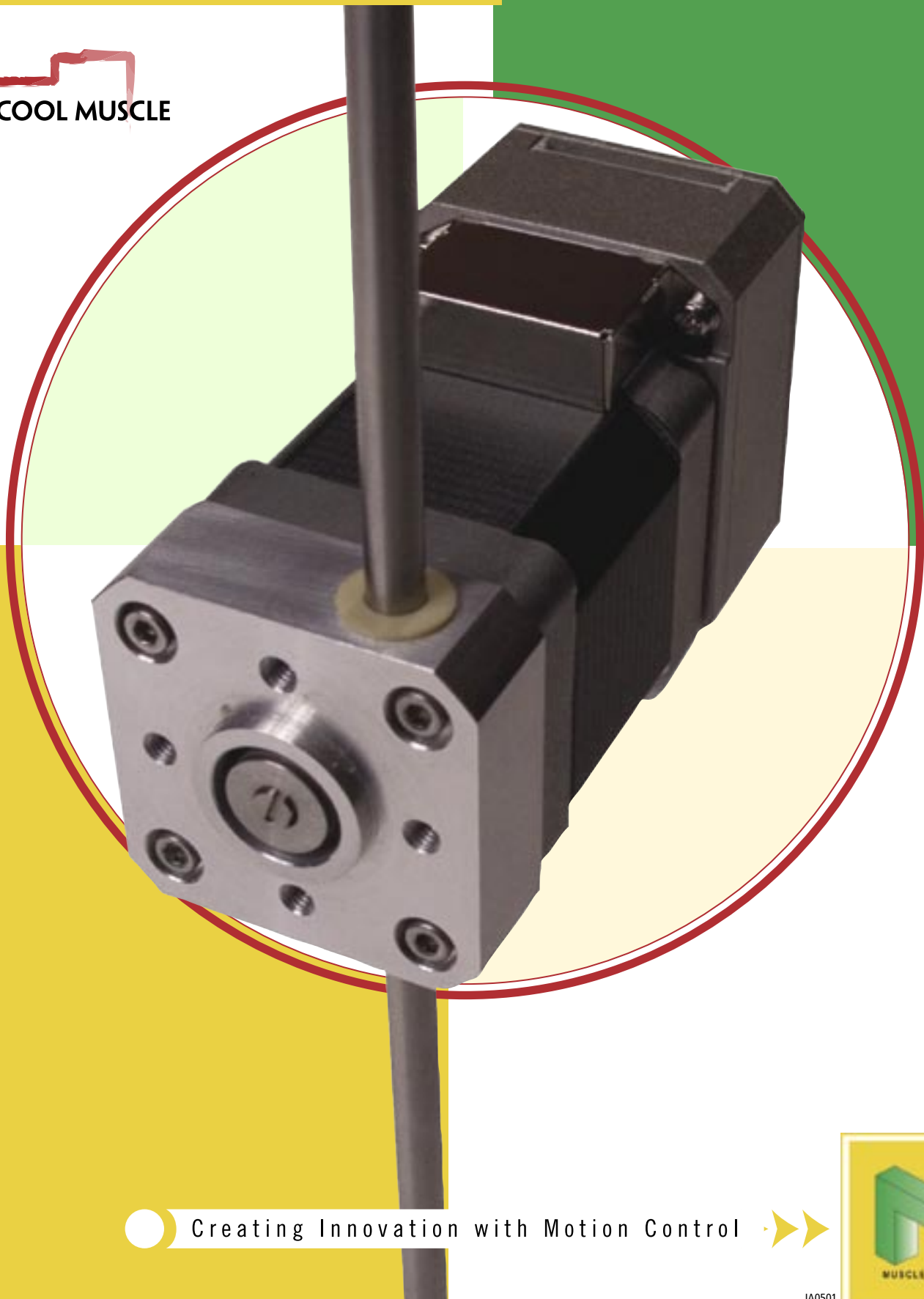

Creating Innovation with Motion Control >>>



COOL MUSCLE

1

Concept

Integrated Vector Drive Servo System

The Cool Muscle is a closed loop vector drive servo system. An intelligent driver with a 32-bit RISC CPU, a magnetic encoder, and power management are built onto the motor. The Cool Muscle excels in performance, size, and cost, offering new ways to design and develop with motion control.



ALL IN ONE SOLUTION

Integrating **Driver, Controller, Encoder, and Motor**, the Cool Muscle is an all in one solution for your motion control.

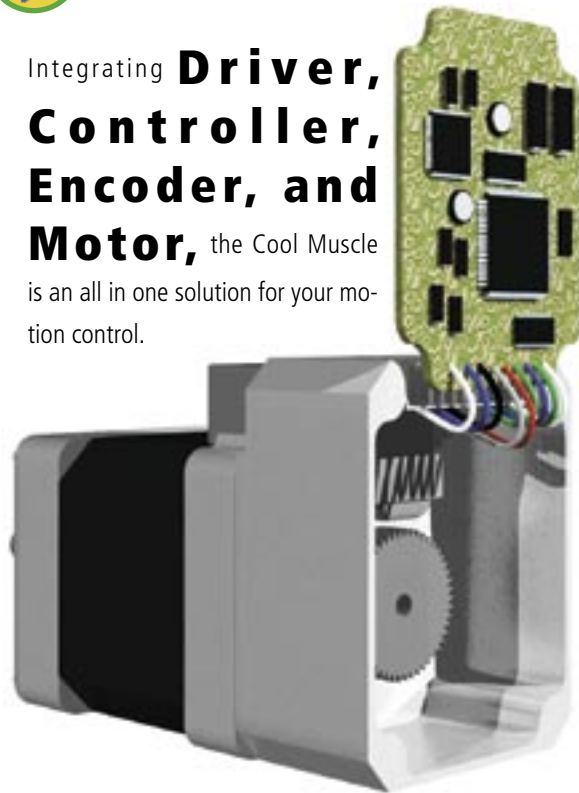

Integrated Controller

Based around a 32-bit RISC CPU, the integrated controller offers a wide range of hardware and software features. Motion programs can be stored with the motor, eliminating the need for driver and controller boxes. Net worked motors can also communicate with each other.



Integrated Driver

A 24VDC sinusoidal driver with regenerative braking implements the Cool Muscle's Vector Driven motions at speeds up to 3000RPM. The closed loop architecture allows the driver to work extremely effectively, resulting in a cool long life servo system.



High Resolution Magnetic Encoder

Minimizing position error and reducing motion ripple can only be achieved with an advanced encoder. The Cool Muscle standard magnetic encoder feeds back position changes as small as 0.0072 or 0.43 arch minutes.



THE POWER OF COOL MUSCLE

Conventional System

A typical conventional slider system requires a driver, controller, origin switch, limit switches and so on, making the whole system messy and bulky.

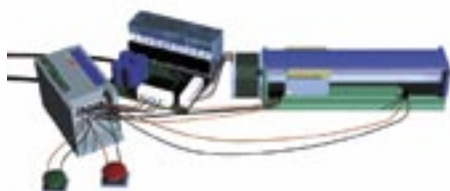

Very hard to differentiate your product.

Cool Muscle System

The Cool Muscle eliminates the need for an external driver box, controller, and switches, making your system compact, and simple.



Leave your competition behind with the Cool Muscle.

Cool Muscle Types

The Cool Muscle supports three different interfaces; Computer, Analog and Pulse. Choose a type that will best suite your need.

C type

C type Cool Muscle is the most versatile and feature packed solution among the two types. C type Cool Muscle can be pre-programmed, dynamically controlled by PC or embedded computer and can be networked for multi-axis applications. Digital signals can also activate stored motion programs, creating a compact, powerful machine with simple controls. C type Cool Muscle can also vary speeds or positions in proportion to voltage input level. Set the max speeds or travel distance with ease by parameters. The V type Cool Muscle is an ideal solution for constant feed systems, and valves.

Solution 1 Preprogram

If your application only requires repetitive motion, you can preprogram the motor, eliminating the need for a controller. Preloaded programs can be executed by a switch, PC or PLC.



A slider system with a pre-programmed C type Cool Muscle.

Solution 2 Dynamic Command

If your application requires complicated motion or arbitrary motion, you can send command dynamically to the Cool Muscle via PC or embedded computers.



A slider system with C type Cool Muscle

Solution 3 Network

C type Cool Muscles can be daisy chained, providing you with a simple and low cost network solution. There are different ways to network C type Cool Muscles to suit your needs.

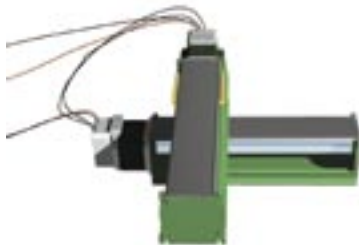

A X-Y system with C type Cool Muscles in a daisy chain network.

Solution 4 Analog Control



A slider system with C type Cool Muscle controlled by a joy stick

P type

Replacing your current pulse driven system with the P type Cool Muscle will save space and remove problems associated with an open loop stepper. P type Cool Muscle supports both CW/CCW and Pulse/Direction.

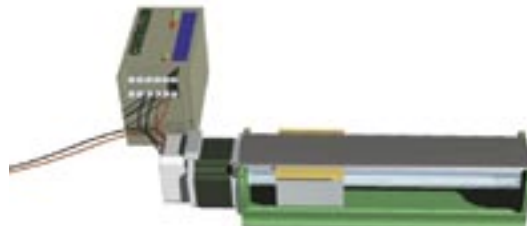

A typical Slider system with P type Cool Muscle

COOL MUSCLE

Features

3

Cool Muscle Features

The Cool Muscle is packed with features that help you reduce the size and cost of your machines while also shortening development time.



Simple and Compact

An intelligent driver with a 32 bit RISC CPU, Magnetic encoder, and power management are all built in right on the motor.



No more driver/boxes. Reduced wiring. Smaller machines. Shortened development time

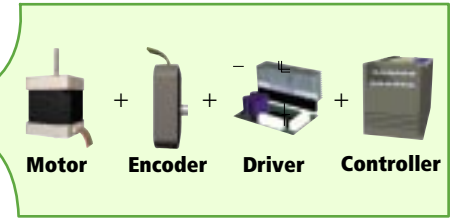

Full Closed Loop System + H^∞

The Cool Muscle is a full closed loop system. With a high resolution magnetic encoder and the intelligent driver board mounted on the back, the Cool Muscle constantly monitors its position, eliminating any missed steps.

The new robust **H infinity** controller tolerates dynamic loads and ensures system stability



Higher repeatability, stability, and accuracy.

Closed Loop System

By receiving position input from the sensor the Cool Muscle knows its position and can correct itself.

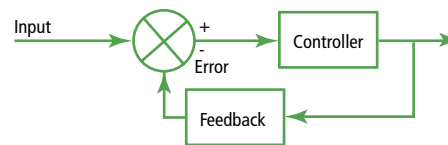

H^∞

Using the newest control technology, the Cool Muscle goes beyond old fashioned static PID control by utilizing the robust **H $^\infty$** control system. **H $^\infty$** responds to dynamic loads across the entire speed range, reduces the need to tune gains, and increases the allowable inertia mismatch.



Smooth and Accurate Movements

The Cool Muscle's high resolution encoder gives you an exceptionally fine placement of 50,000 units per rotation. The Cool Muscle uses Vector Drive control, resulting in incredibly smooth motion even at low speeds not possible with microstepping drivers.



Performance levels similar to AC servos at a fraction of the price.

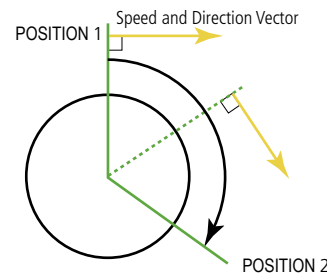

Vector Drive Control

Vector Drive is a control technique used in servo systems. Vector Drive Control is a completely different technique from micro-stepping. Unlike micro-stepping Vector Drive Control is not subject to resonance problems and produces smooth movements.



Cool Operation

The Cool Muscle's power management monitors and provides the optimum current based on load, keeping the motor cool. In addition, using a stepping motor, the Cool Muscle generates high torque at low speeds.



Longer motor life. Increased power efficiency. Great for enclosed spaces. Reduced need for gear boxes.

The Cool Muscle applies optimum current to produce motion whereas an open loop stepper always uses the maximum current.

The Cool Muscle has high torque even at low speeds. The Cool Muscle excels at both smooth motion and slow speeds.

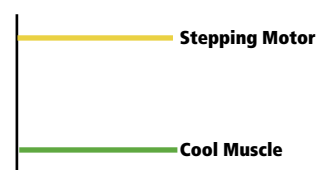



Various Interfaces

The Cool Muscle can be controlled by various methods, including Pulse, Analog, Computer and PLC. Choose the type that best suits your needs.



Minimum modification required to your system.

A wide range of solutions for your system.



Programmable

Program the Cool Muscle to create the motion you need. Define motion profiles and create programs using easy-to-understand Cool Muscle Language (CML). Motion programs you create can be downloaded to the Cool Muscle. The programs can be executed via PC, embedded computer or simply using I/Os.



Great solution for repetitive motion. Simple and compact machines.





User Definable Parameters

Define the character of your Cool Muscle to suit your needs. The Cool Muscle gives you over 35 parameters. Parameters can easily be set using CML.



Flexibly change your motor characteristics.

	Control	Variations
 P type	Pulses	CW/CCW Step/Direction
 C type	PC Embedded Computer PLC Switch	Pre-Programmed Dynamic Command
	Analog Input	Position Speed

CML

Cool Muscle Language is a set of ASCII commands that lets you easily create motion programs. Programs you create can be downloaded to the Cool Muscle via free software from Muscle Corporation, Cool Works Lite or any standard terminal program.

P1=1000
P2=2000
S1=200
S2=300
A1=50
A2=150
T1=20

Define motion profiles such as speed, acceleration, position and timer.

B1
A1,S1,P1
S2,P2,P1
C2
B2
A2,S1,P3

Define motion programs using the motion profiles defined above.

- K46=1** Origin search set to automatic origin search using bumper.
- K48=10000** Origin offset distance set to 10000 pulses.
- K58=200000** Software limit + side set to 200000 pulses.
- K52=50** position P gain set to 50.
- K53=250** Velocity P gain set to 250.
- K54=2** I gain set to 2.
-
-

USEFUL PARAMETER EXAMPLES

Unique Home Search Method

A home search parameter lets you select a home search method. Eliminate the need for home switches using our unique home search technique. Home can be determined using a hard-stop/bumper instead of using a home switch. The Cool Muscle hits a bumper at very low speed and keeps pushing until it reaches a specified current level, at which the motor determines that it has reached home. This method eliminates the need for home switch and wiring.

Software limit

You can set software limits using Cool Muscle parameters. Set limits on both CW and CCW sides to eliminate limit switches.

These two software features just saved you the cost of three sensors and the time needed to install wiring and calibrate them.

COOL MUSCLE

5

Features



Programmable I/Os

Configure and assign multiple functions to I/Os on the Cool Muscle. Cool Muscle has 4 inputs and 2 outputs that can be used as digital, analog, serial or pulse counter (Input only). The new Cool Muscle lets you assign a function to each point of a signal.



Custom I/O. Flexible application of powerfully built in features.

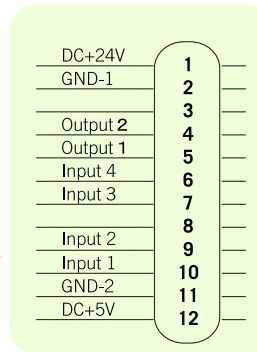

Input Functions examples:

- Origin sensor
- Manual feed
- Manual Jog
- Execute Bank 1,2,3
- Origin Search
- Motor Free
- Enable Motor
- Execute Next Step
- Execute Previous Step

Output Functions examples:

- Alarm
- In-position
- Analog Output for monitoring



Virtual Input Signal

Make the most of the I/O ports by taking advantage of Cool Muscle's unique virtual signal technique. The Cool Muscle creates two signals based on a single input signal by setting a time delay between the two signals, allowing you to assign multiple functions to a single input.



Eliminates the need for external I/O board.

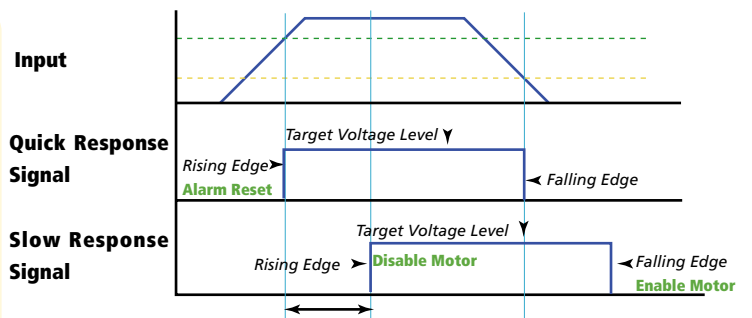

Quick and Slow response signals example: You can assign Alarm Reset, Motor Free and Enable Motor to the rising edge of Quick response, target voltage level and falling edge of Slow response signals respectively. Input functions are set by parameters.



Advanced Motion

Change speeds or accelerations while the motor is in operation. The Cool Muscle supports advanced motions such as continuous PTP and PTP motion with different accelerations and decelerations, Push mode and more. The powerful push mode is also standard allowing for electric simulation of common pneumatic operations.

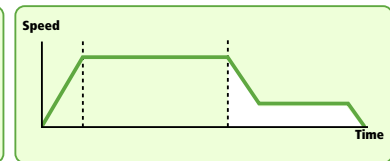
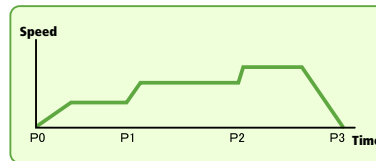

Continuous PTP: There is no stops in motion between origin and P3. Speed and acceleration are changed at each point.

Push Mode: Push mode mimics a typical pneumatic cylinder motion. It keeps pushing for a given time and at a set current level when a motor encounters a resistance such as bumper and stopper.



Network

The Cool Muscle provides you with different networking solutions that best suit your needs. Connect multiple Cool Muscles in a daisy chain style network. In the daisy chain network Cool Muscles can tell other motors to activate programs as well as receive commands from a computer or an embedded controller.



Simple network solution that lowers your cost.

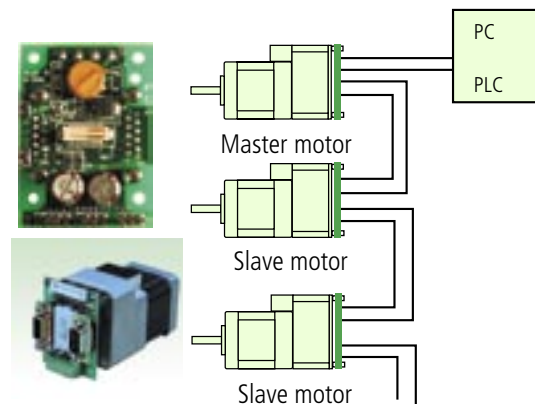

PRODUCT NAME FORMAT

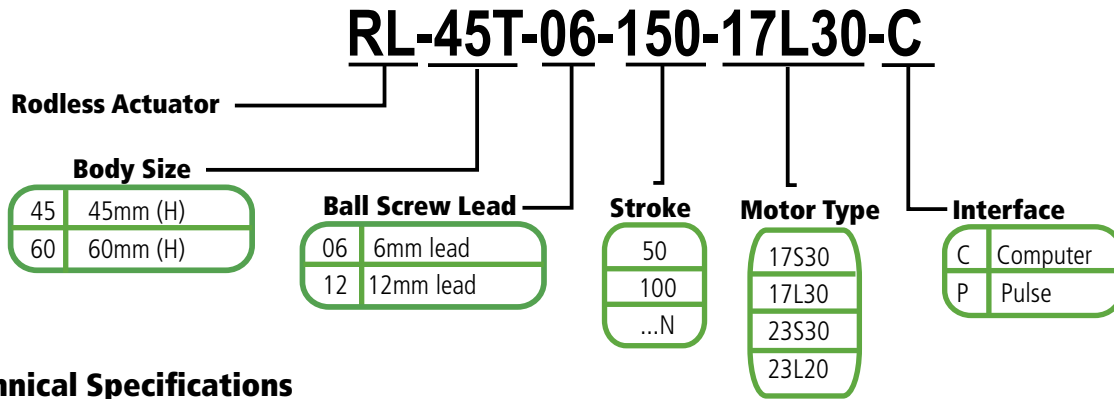

Technical Specifications

	RL-45T		RL-60T	
Ball Screw Lead (mm)	12	6	12	6
Max Speed (mm/sec)	600	300	600	300
Rated Force (N)	40	80	67	133
Max Force (N)	117	238	201	402
Load Capability (H)	5	10	8	16
Loda Capability(V)	1.5	3	2.5	5
Ball Screw Lead (mm)	12	6	12	6
Ball Screw Diameter (mm)	8		12	
Repetitive Accuracy(mm)	+/-0.020			
Backlash(mm)	0.1			
Moment (Nm)	Ma=Mb=12 Mc=31		Ma=Mb=25.7 Mc=58	
Life(km)	5000			

Moments

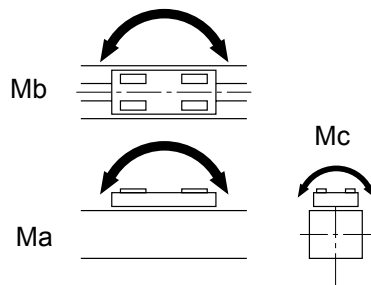

Product Cutaway

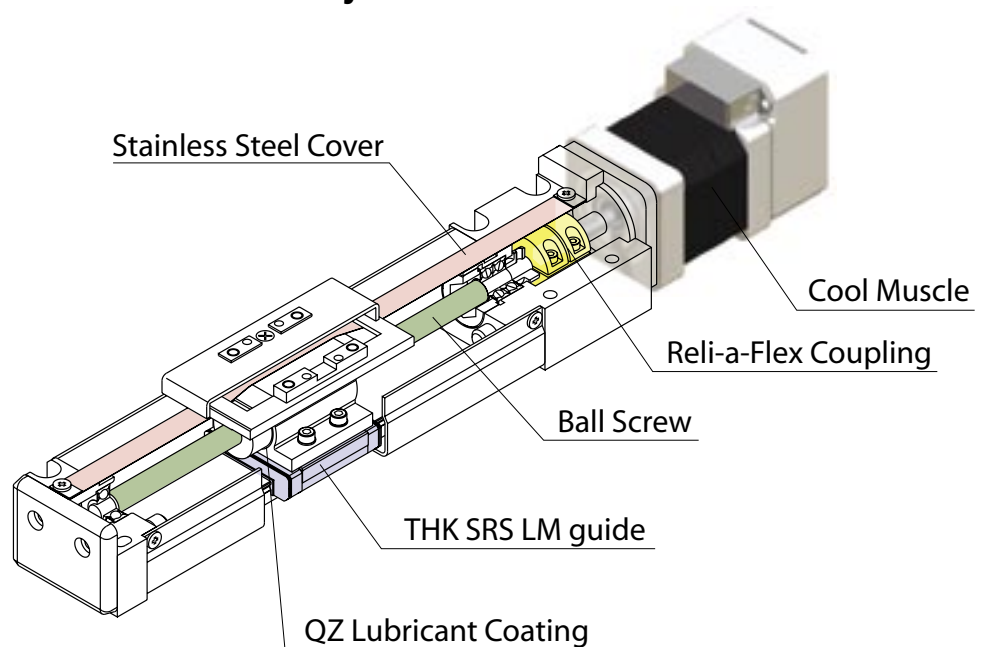

COOL MUSCLE

7

RL-45T INTELLIGENT ACTUATOR

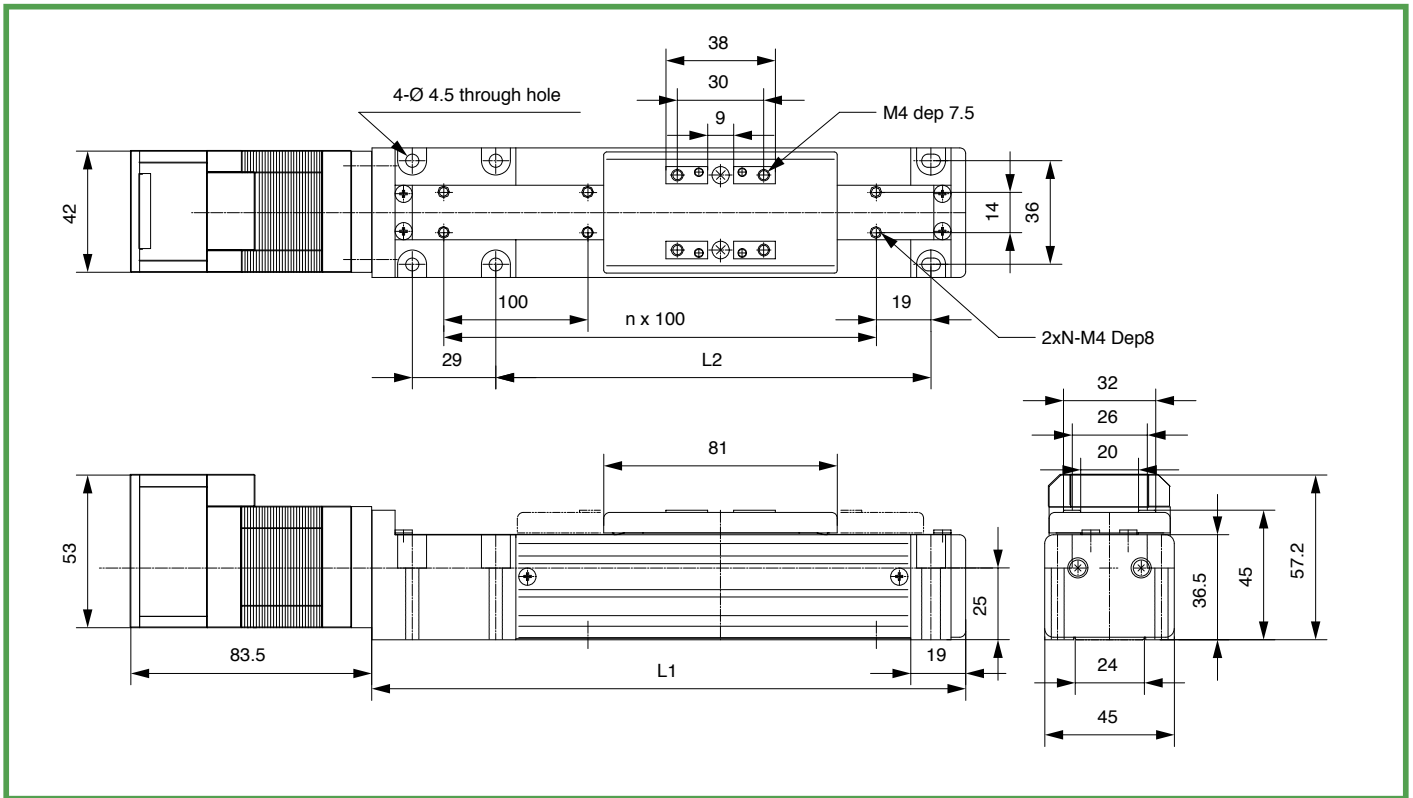

Unit (mm)

Stroke	Effective Stroke	Mechanical Stroke	L1	L2	n	N	Weight(Kg)
0050	50	60	206	151	1	2	1.30
0100	100	110	256	201	2	3	1.41
0150	150	160	306	251	2	3	1.52
0200	200	210	356	301	3	4	1.62
0250	250	260	406	351	3	4	1.73
0300	300	310	456	401	4	5	1.84
0350	250	360	506	451	4	5	1.95
0400	400	410	556	501	5	6	2.07
0450	450	460	606	551	5	6	2.17
0500	500	510	656	601	6	7	2.28

All RL actuators include the same function set and wiring specifications as the Cool Muscle integrated servo system allowing for accurate and reliable positioning in both PLC control environments and PC control systems. The RL45T accepts both the CM1-C-17S30 and CM1-C-17L30 Cool Muscle motors.

Please refer to the Cool Muscle Integrated Servo System catalog for motor speed specifications.

The RL actuators use a wide THK SRS LM guide for stability and linear precision. Quiet motion is achieved through the use of the single piece Reli-a-Flex shaft coupling and the ball retainer of the SRS LM guide. Additionally, the RL actuator's ball screw has a special coating called QZ that lengthens the maintenance cycle and life time of the actuator.

COOL MUSCLE

Specifications

9

PRODUCT NAME FORMAT

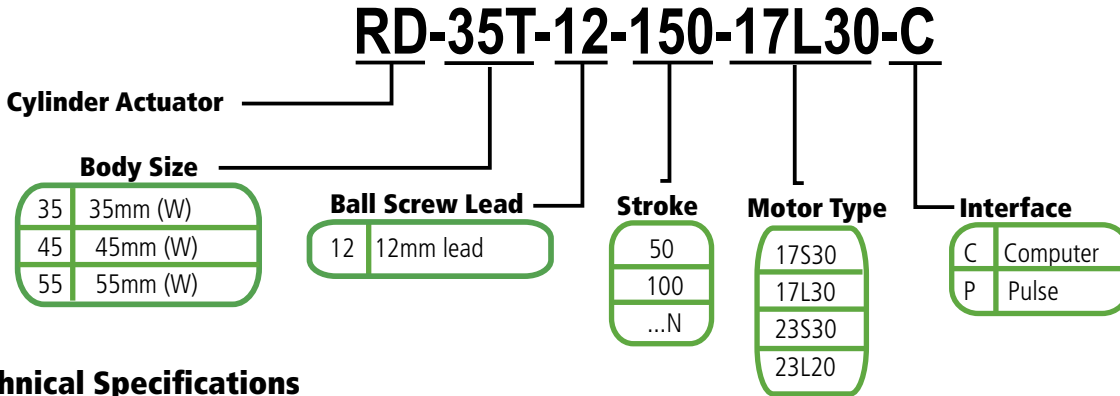

Technical Specifications

	RD-35T	RD-35T	RD-55T
Max Speed (mm/sec)	600	600	600 (470 for 300 stroke)
Rated Force (N)	34	67	123
Max Force (N)	103	201	370
Load Capability (H, 0.3G) (Kg)	3.4	7	23
Load Capability (V, 0.3G) (Kg)	1.6	3.1	5.9
Ball Screw Lead (mm)		12	
Ball Screw Diameter (mm)		8	12
Repetitive Accuracy(mm)		+/-0.020	
Rod Diameter(mm)	16	20	25
Stroke(mm)	50/100/150	50/100/150/200	50/100/150/200/250/300
Life(km)		5000	

Product Cutaway

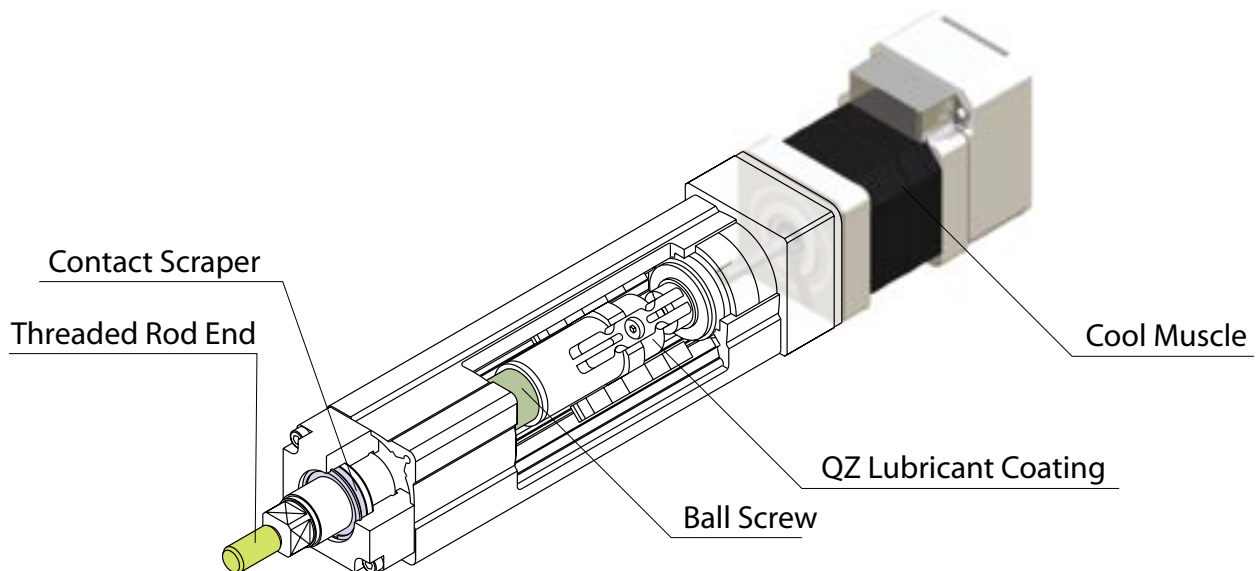

RD-35T INTELLIGENT ACTUATOR

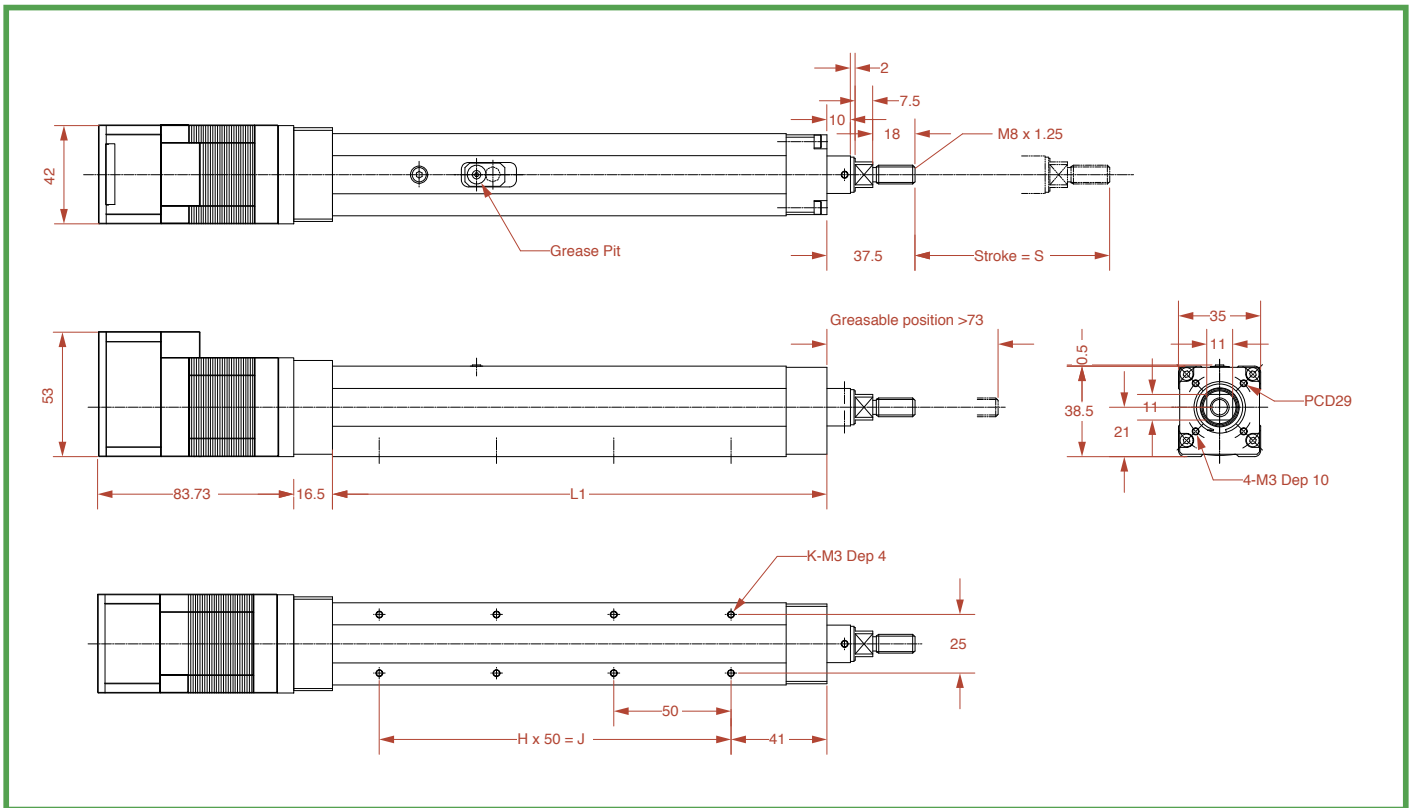

Unit (mm)

Stroke	Effective Stroke	L	L1	H	J	K	Weight(Kg) (w/17S30)
0050	50	240	161	2	100	6	1.2
0100	100	290	211	3	150	8	1.4
0150	150	340	261	4	200	10	1.5

An excellent replacement for pneumatic cylinders, the RD series actuator offers fast, precise motion without any of the noise associated with air driven systems. Overall system complexity and maintenance is greatly reduced resulting in a cost effective solution for your next application.

All RD actuators include the same function set and wiring specifications as the Cool Muscle integrated servo system allowing for accurate and reliable positioning in both PLC control environments and PC control systems. The RD-35T accepts both the 17S30 and 17L30 Cool Muscle motors.

Please refer to the Cool Muscle Integrated Servo System catalog for motor specifications.

As with the RT series, the RD actuator's ball screw is coated with QZ lubricant. This reduces maintenance and lengthens the overall life of the cylinder.

COOL MUSCLE

Specifications

11

RD-45T & RD-55T INTELLIGENT ACTUATORS

RD-45T

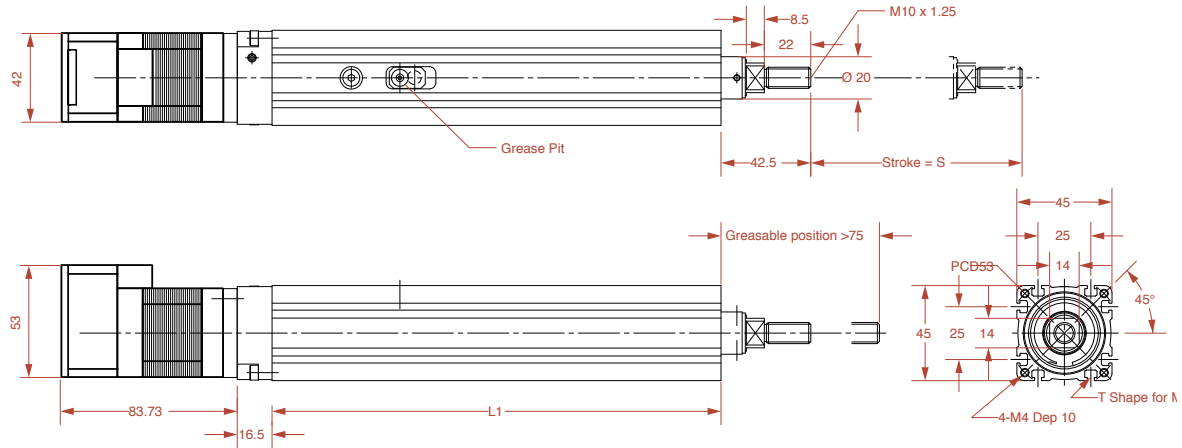

RD-55T

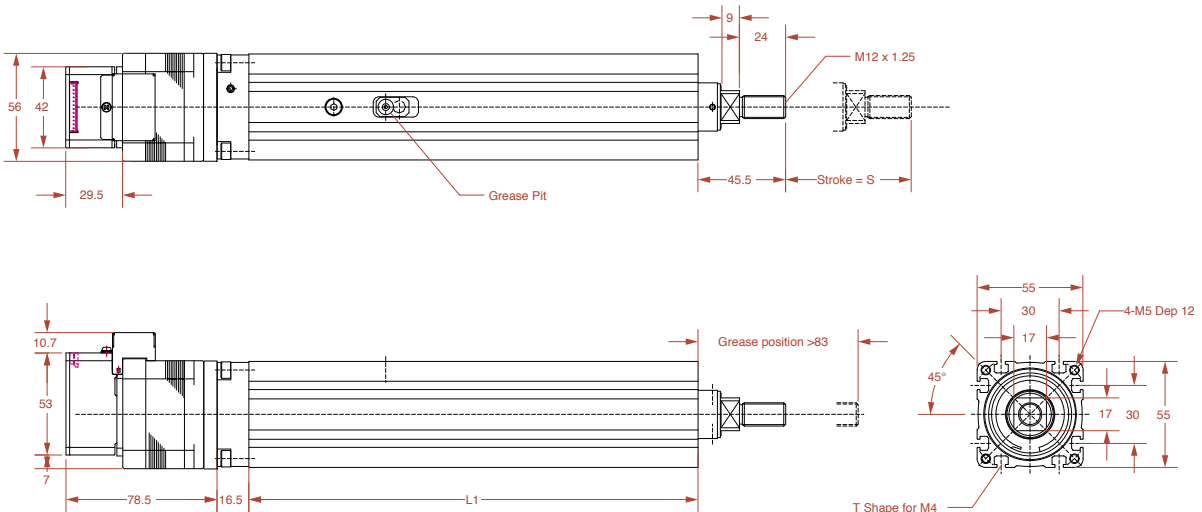

Unit (mm)

RD-45T	Stroke	Effective Stroke	L	L1	Weight(Kg)
	0050	50	238.5	162.5	1.6
	0100	100	288.5	212.5	1.7
	0150	150	338.5	262.5	2.1
	0200	200	388.5	312.5	2.4

RD-55T	Stroke	Effective Stroke	L	L1	Weight(Kg) (w/23S30)
	0050	50	273	183	2.4
	0100	100	323	233	2.8
	0150	150	373	283	3.2
	0200	200	423	333	3.5
	0250	250	473	383	3.9
	0300	300	523	433	4.3

PRODUCT NAME FORMAT

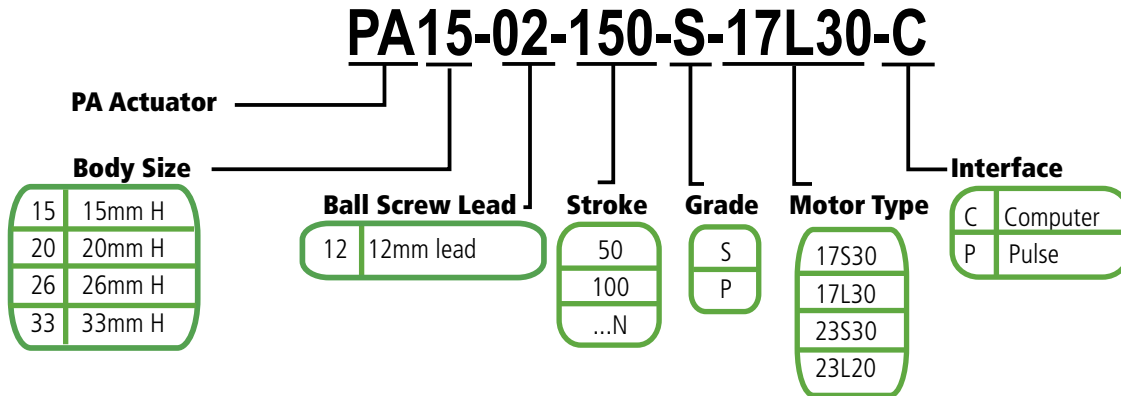

Technical Specifications (units: mm)

Model	Ball Screw Lead	Outer Rail Length	Stroke	Max. Velocity (mm/s)	Force (N)	Repeatability (Running Parallelism)	Backlash (P Grade)	Starting Torque
PA15 (w/11L30)	1	75	31	50	489	+0.004 (0.020)	0.010	0.4
		100	56					
	2	125	81	100	244			
		150	106					
PA20 (w/11L30)	1	175	131	50	489	S Grade = +0.010 P Grade = +0.003	0.020 (0.003)	0.5
		200	156					
PA26 (w/17L30)	2	75	31	100	1600	S Grade = +0.010 P Grade = +0.003	0.020 (0.003)	1.5
		100	56					
	6	125	81	100	1600			
		150	106					
PA33	6	175	131	(w/17L30) 300	533	S Grade = +0.010 P Grade = +0.003	0.020 (0.003)	7
		200	156	(w/23L20) 200	1308			
	10	250	169	100	320			
		300	219					
	10	300	211	100	320			
		400	311					
	10	500	411	(w/17L30) 500	320	S Grade = +0.010 P Grade = +0.003	0.020 (0.003)	7
		600	511	(w/23L20) 333	785			
	10	600	511	100	785			

COOL MUSCLE

13

Specifications

PA15 Series

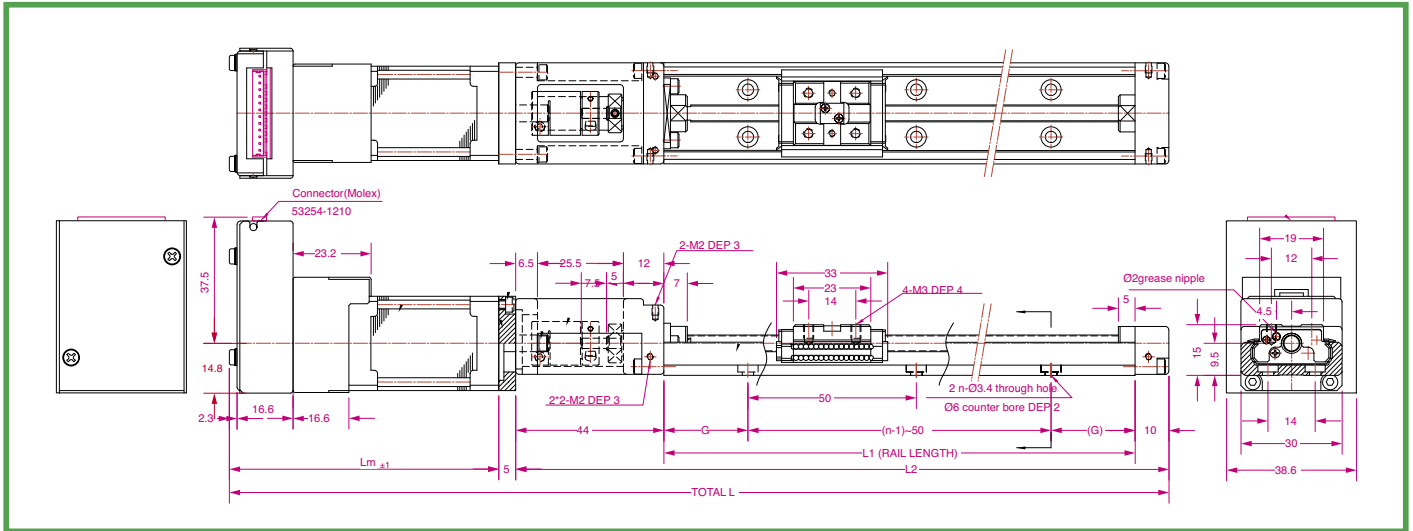

Unit (mm)

Rail Length L1	Stroke	L2	Motor Lm		L		G	n
			w/11S30	w/11L30	w/11S30	w/11L30		
75	31	129	66	80	200	214	12.5	2
100	56	154			225	239	25	2
125	81	179			250	264	12.5	3
150	106	204			275	289	25	3
175	131	229			300	314	12.5	4
200	156	254	325	339	25	4		

PA20 Series

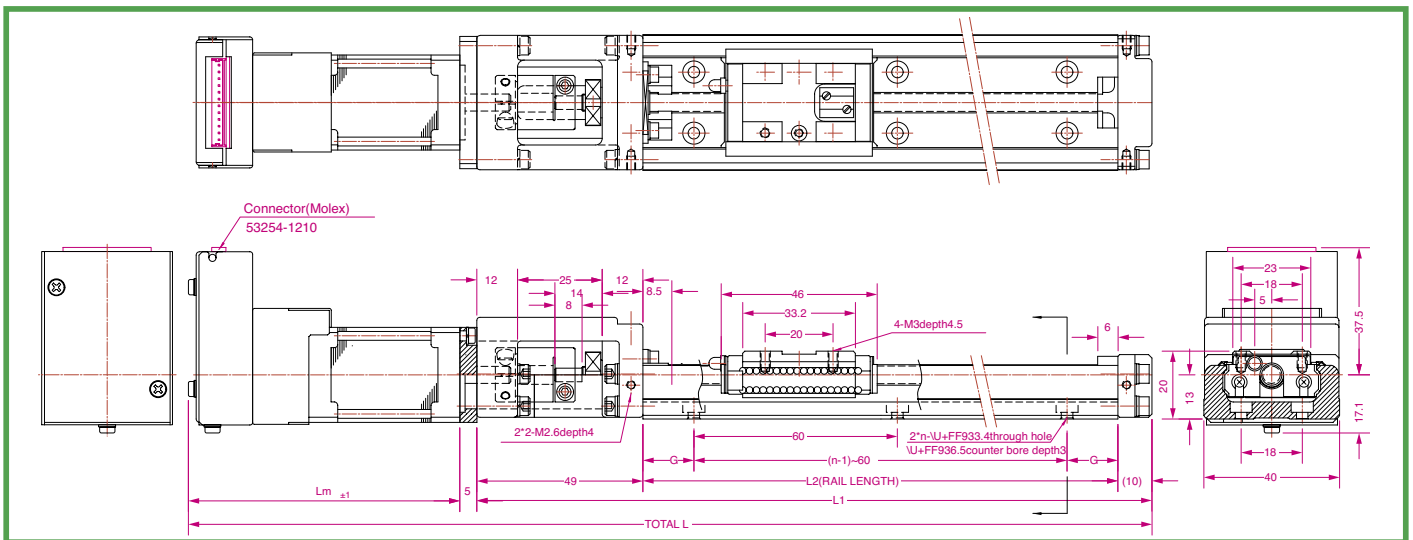

Unit (mm)

Rail Length L2	Stroke	L1	Motor Lm		L		G	n
			w/11S30	w/11L30	w/11S30	w/11L30		
100	41	159	66	80	230	244	20	2
150	91	209			280	294	15	3
200	141	259			330	344	40	3

PA26 Series

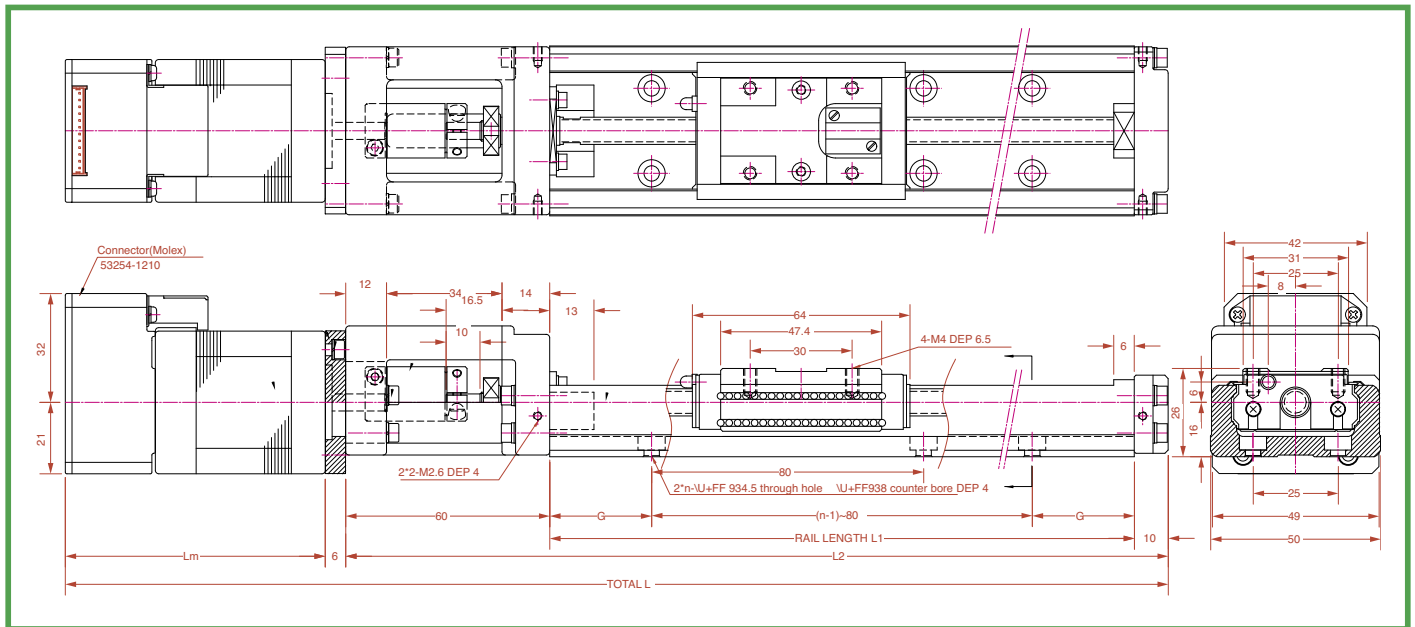

Unit (mm)

Rail Length L1	Stroke	L2	Motor Lm		Total L		G	n
			w/17S30	w/17L30	w/17S30	w/17L30		
150	69	220	60.5	76.5	286.5	302.5	35	2
200	119	270			336.5	352.5	20	3
250	169	320			386.5	402.5	45	3
300	219	370			436.5	452.5	30	4

The PA Series intelligent actuator is for applications requiring high accuracy and a long life. Repeatability down to 3 microns and a running parallelism as straight as 10 microns are possible with the Precision grade PA Actuator.

Carriage heights vary from 15mm to 33mm, providing a solution for tight spaces and for large loads.

All PA Series sliders are based on established components from the best manufacturers. Each intelligent actuator is comprised of Muscle's Cool Muscle, connected to THK's KR series ball screw actuators, with Reliance Gear's Reli-a-Flex single piece shaft coupling. The result is a quiet, strong, integrated package from controller through to slider.

Please lubricate the PA actuator every 100km to maintain peak performance. Clean room grease is available upon request.

COOL MUSCLE

15

PA33 Series

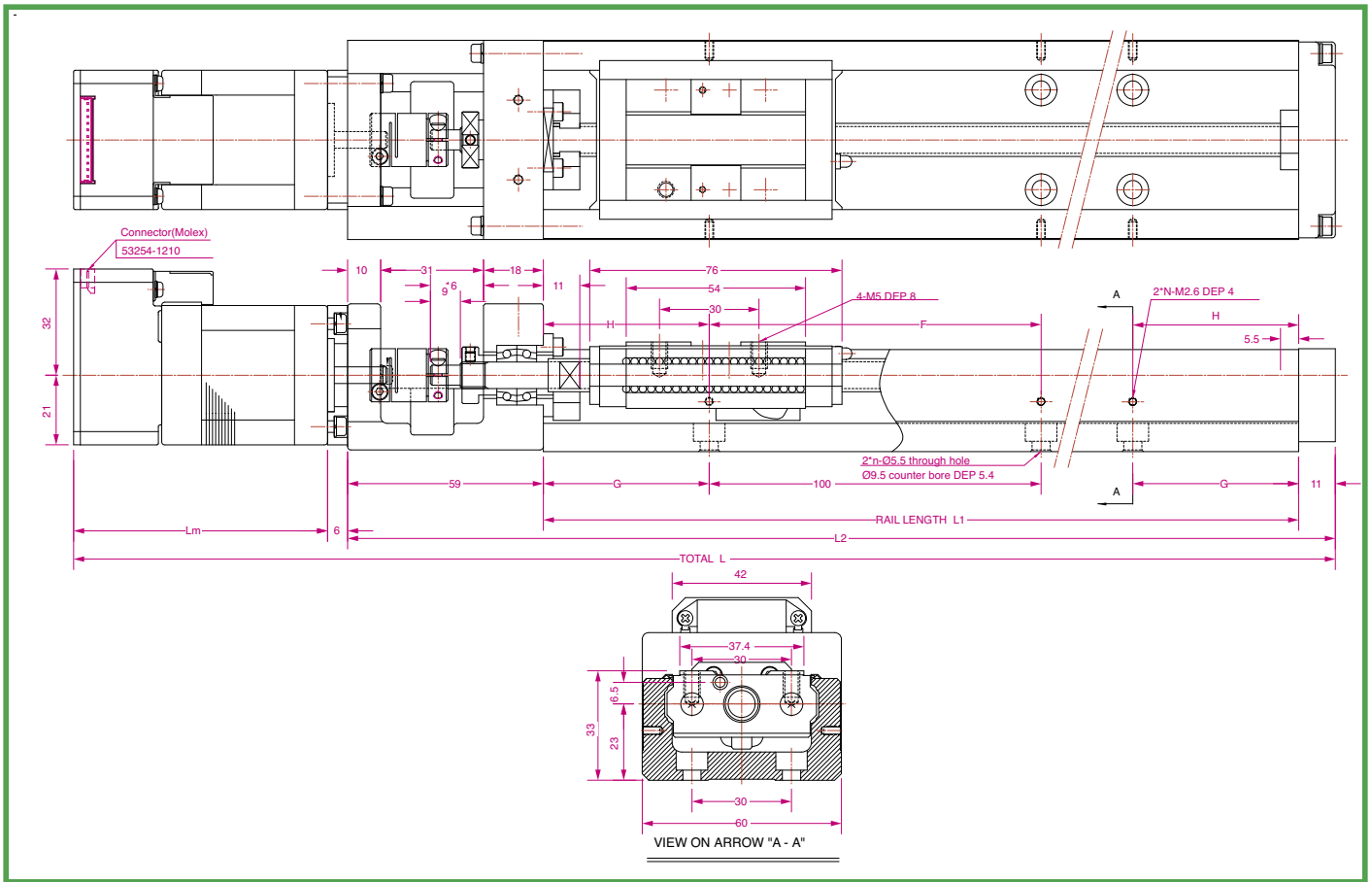

Unit (mm)

Rail Length L1	Stroke	L2	Motor Lm		Total L		G	H	F	N	n
			w/17S30	w/17L30	w/17S30	w/17L30					
150	61	220	60.5	76.5	286.5	302.5	25	25	100	2	2
200	111	270			336.5	352.5	50	50	100	2	2
300	211	370			436.5	452.5	50	50	200	2	3
400	311	470			536.5	552.5	50	100	200	2	4
500	411	570			636.5	652.5	50	50	200	3	5
600	511	670			736.5	752.5	50	100	200	3	6

All PA Series sliders use Reliance Gear Company Lt.d Reli-a-Flex™ couplings. These couplings are matched to motor torque limits and shaft sizes. The positional accuracy and axial flexibility of the Reli-a-Flex™ ensures that each PA slider operates to its maximum potential.

More information on the Reli-a-Flex™ coupling can be found at the end of this catalog or on our web site at:
www.coolmuscle.com



INTEGRATED TUBULAR RACK ACTUATOR - RRA11

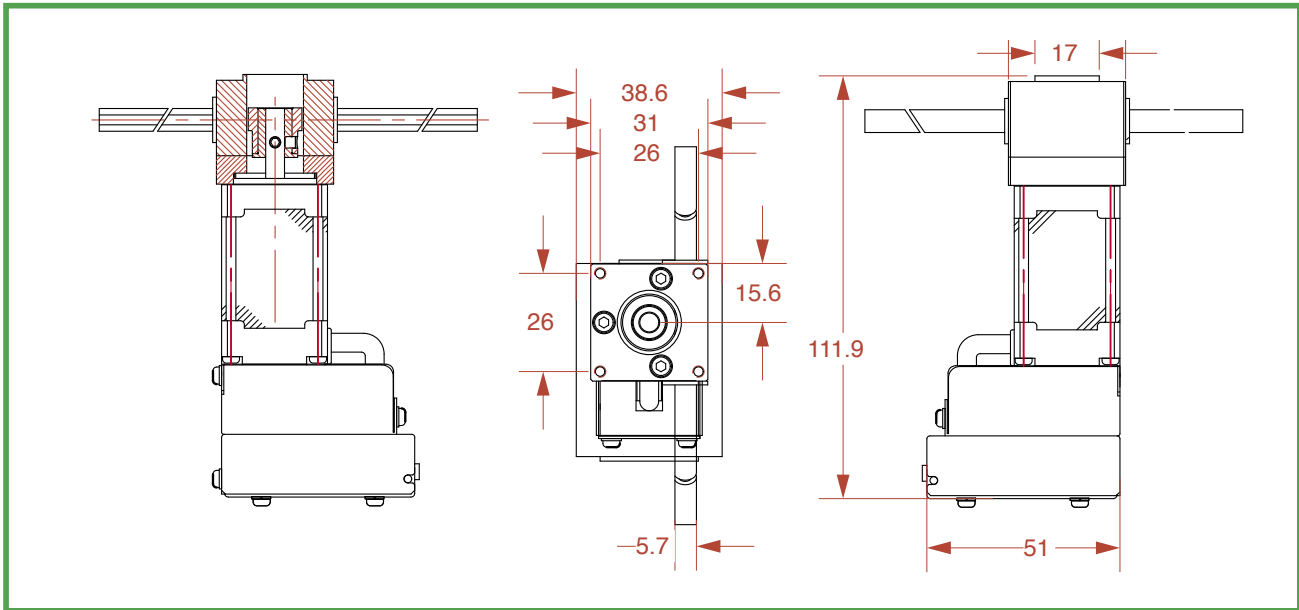

Specifications	Unit	RRA11	RRA17	RRA23
Rack Type	69	OD 6mm, bore 3.4mm, 316 stainless steel		OD 12mm, 440C stainless steel
Stroke	mm	150mm-500mm, 50mm increments		
Axial Load	N		3	90
Moment Load	N		12	200
Positioning accuracy	mm		-+0.02	0.025
Max. Speed	mm/sec		300	200
Repeatability	mm		0.025	0.025
Backlash			0.08	0.06
Voltage		24V DC		

The tubular rack and pinion system is designed around lubrication free PEEK polymer components to provide a worry free Z-axis actuator. As the rack is hollow, vacuum, wires, or liquids for dispensing can travel the length of the rack resulting in a light weight, high speed transport system.

The RRA23 is designed specifically for applications requiring a compact, accurate system for moving heavier components or exerting greater forces on a target. The RRA23 is based on the CM1-C-23L20 Cool Muscle.

The RRA11 and RRA17 can be ordered with metal pinion gears, increasing the Axial Load beyond 25N.



COOL MUSCLE

17

INTEGRATED TUBULAR RACK ACTUATOR - RRA17

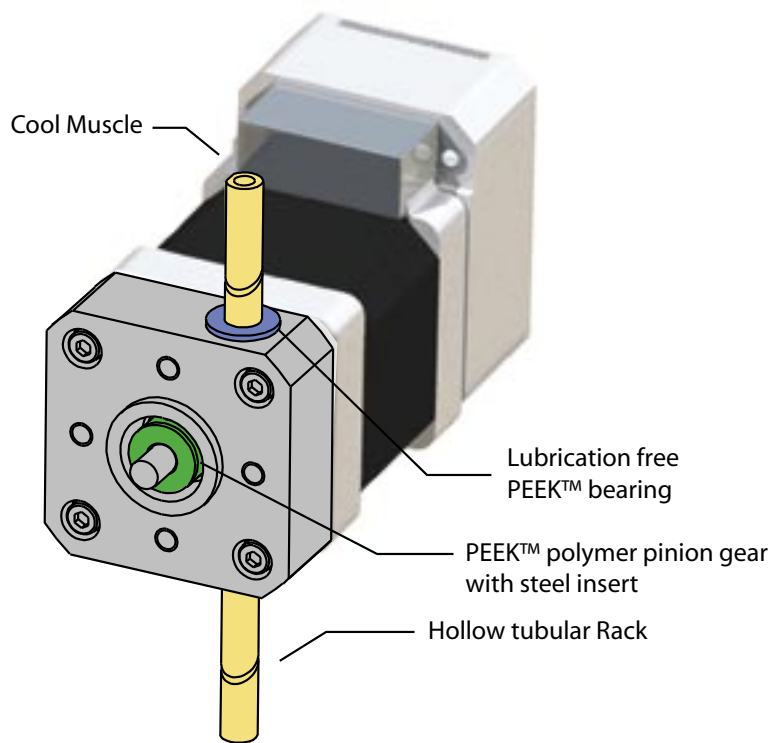
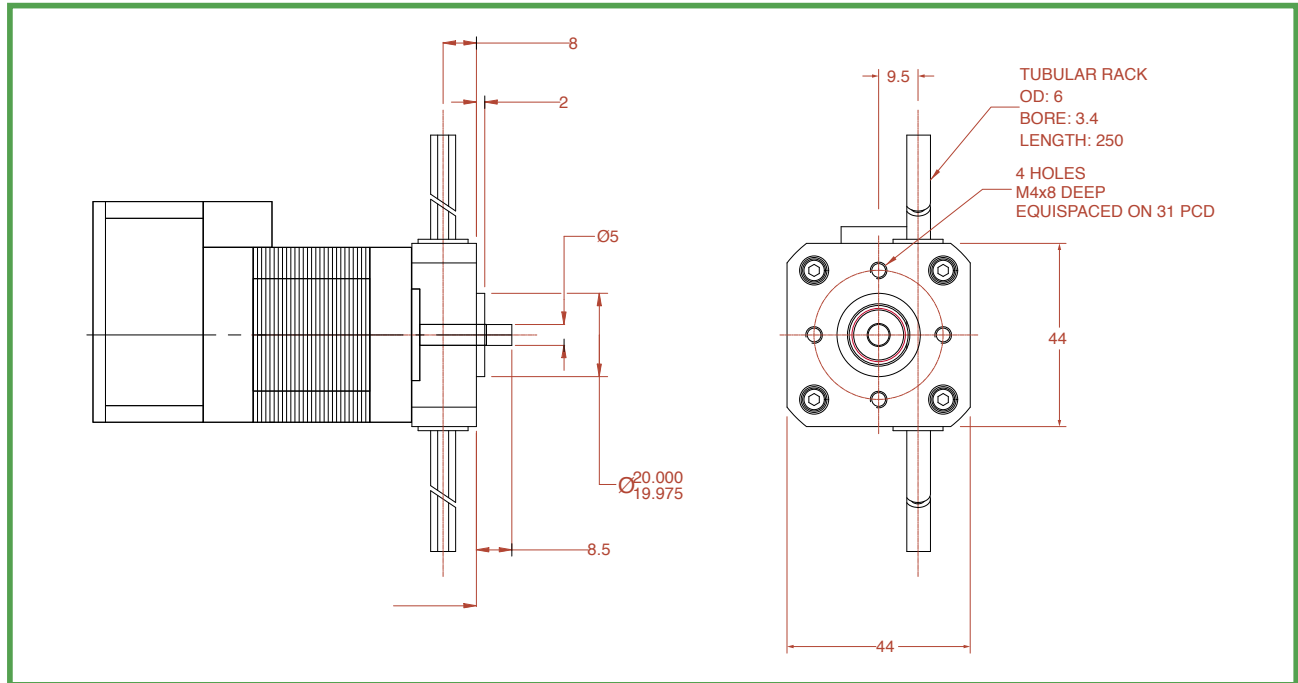

Removing the size and weight associated with linear guides and ballscrews, the Rack actuator provides a light weight solution for dispensing or transporting. Multi-axis systems will respond more quickly and require less force to move and stop accurately.

Utilizing the Cool Muscle's integrated intelligence will also simplify wiring and control design. A single input can trigger a series of moves, or a serial connection allows for dynamic control.

When requesting information, please specify any modifications required to the rack to allow for fittings.

PRODUCT NAME

RCSA20C-8-5

Basic Part#

Size

C:Clamp
S:Set

Bore size
Ø B1-B2

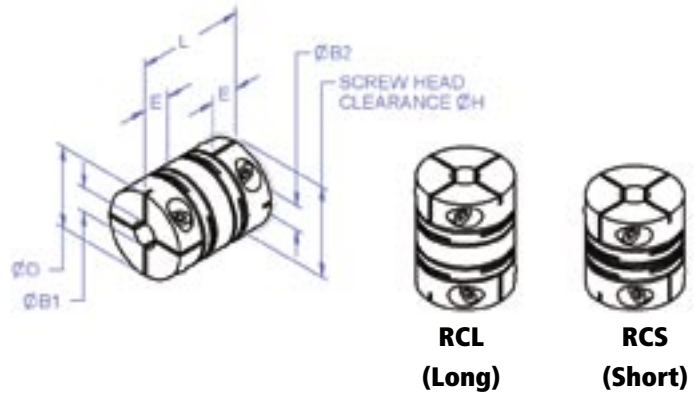

BORE SIZES AND DIMENSIONS

Basic part#	Material	Size	Standard bore sizes ØB1 and ØB2 (Bore tolerance : +0.020/-0.00)	O/D ØD	ØH	Length H	Hub Length E	Fitted Screw
RCS (Short)	A (Aluminum)	13C	3 4 5 6	13.0	14.5	16.8	5.0	M1.6
		16C	3 4 5 6 8	16.0	18.0	17.5	5.9	M2
		20C	4 5 6 8 10	20.0	21.8	21.5	6.6	M2.5
		25C	5 6 8 10 12	25.0	26.9	25.8	7.6	M3
RCL (Long)		13C	3 4 5 6	13.0	14.5	20.0	5.0	M1.6
		16C	3 4 5 6 8	16.0	18.0	23.5	5.9	M2
		20C	4 5 6 8 10	20.0	21.8	26.0	6.6	M2.5
		25C	5 6 8 10 12	25.0	25.0	34.0	7.6	M3

TECHNICAL SPECIFICATIONS

Basic part#	Material	Size	Torsional Stiffness mNm/arc min	Radial Compli- ance microns/N	Misalignment			Max Mass g
					Parallel mm	Angular deg	Axial mm	
RCS (Short)	A (Aluminum)	13C	13.09	29.2	0.08	2.5	±0.30	4.4
		16C	20.36	28.9	0.10	2.5	±0.40	8.6
		20C	33.45	23.4	0.12	3.0	±0.50	14.9
		25C	52.94	20.0	0.16	3.0	±0.70	27.5
RCL (Long)		13C	15.56	64.3	0.15	2.5	±0.30	5.5
		16C	24.43	65.1	0.20	2.5	±0.40	10.6
		20C	40.43	62.0	0.25	3.0	±0.50	18.7
		25C	66.03	82.2	0.40	3.0	±0.70	38.5

TORQUE AND SPEED CAPACITY

Basic part#	Size	Typical Torque Capacity			Max Speed
		Reversing (Nm)	Non Rev (Nm)	Peak (Nm)	
RCS (Short)	13C	0.35	0.45	0.50	12000
	16C	0.55	0.85	1.25	10000
RCL (Long)	20C	0.95	1.45	2.45	7500
	25C	1.55	2.35	3.90	5000

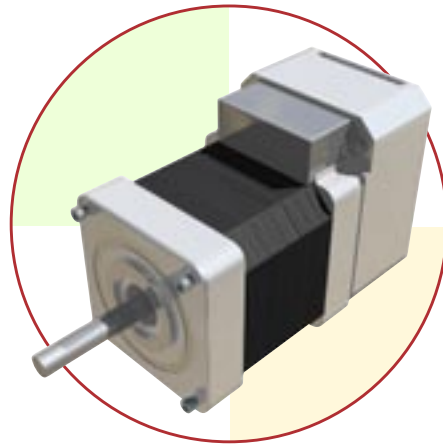

www.coolmuscle.com



Myostat Motion Control
17817 Leslie Street, Unit 43
Newmarket Ontario Canada L3Y 8C6
Tel: 905-836-4441 Fax: 905-836-1214
www.coolmuscle.com